



(EMBARC)



designed by:

Zml

table of contents

1. Inspiration >

2. Wordlist

3. Metrics

4. Glyphs

5. Samples

6. Usage

7. Colophon

The inspiration for the Embarc typeface design originates from various typefaces of greatness that came before me. The Embarc font family appears similar to other typefaces but, it's letter forms allow it to stand on its own. This is my representation of the sans serif style typeface becoming very popular in today's technology and new media filled world.

The Embarc font family functions strongly in user interface designs and the new media world of today. The square letter forms make it ideal for type on screen too. Way-finding, maps with directions, and, small signage as well as text meant for reading at a human scale create even more ideal uses for the font family. Essentially, the square letter forms have subtle understated details which makes this a versatile typeface, capable of delivering any kind of message while staying out of the way.

The first weight created in the Embarc font family is Light.

table of contents

1. Inspiration

2. Wordlist >

3. Metrics

4. Glyphs

5. Samples

6. Usage

7. Colophon

tech
modern
sans serif
clean
readable
details
fine print
user flow
visual
interface
screen
journey
interaction

table of contents

1. Inspiration

2. Wordlist

3. Metrics >

4. Glyphs

5. Samples

6. Usage

7. Colophon

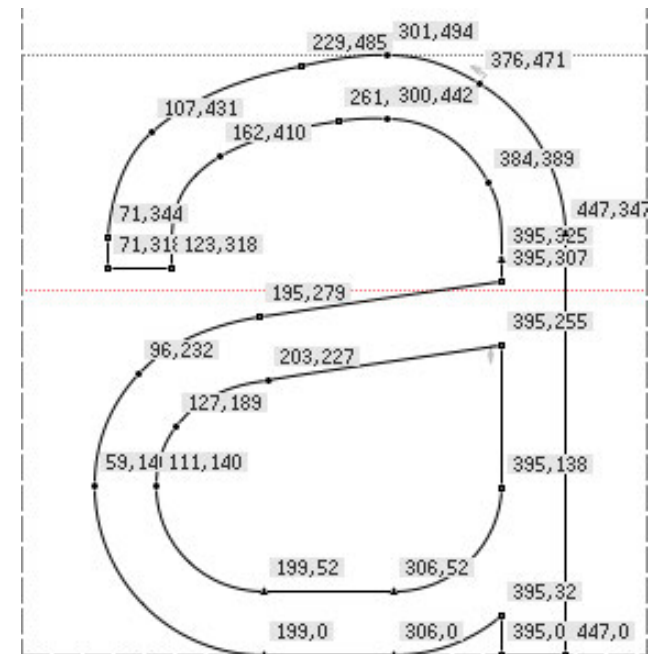
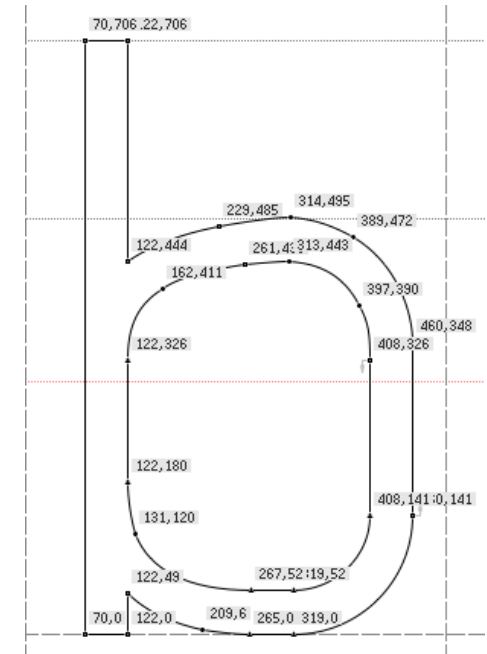
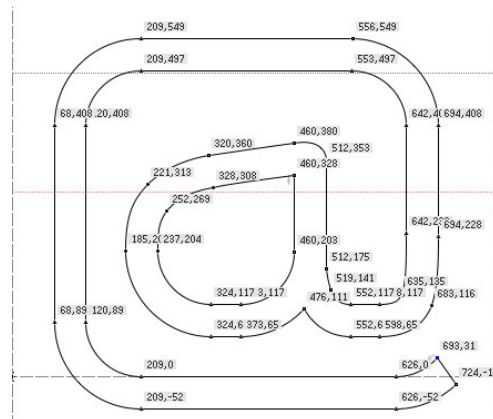
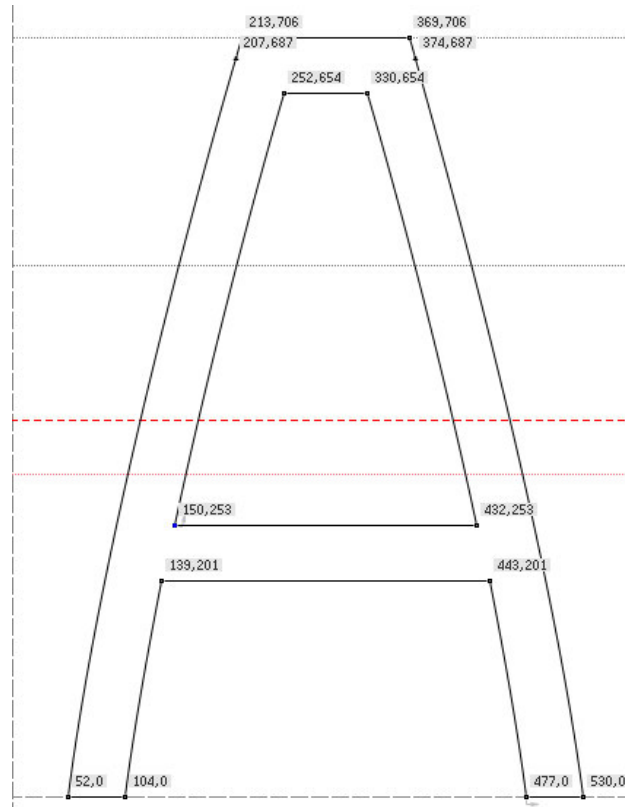

table of contents

1. Inspiration

2. Wordlist

3. Metrics

4. Glyphs >

5. Samples

6. Usage

7. Colophon

uppercase

A B C D E F G
H I J K L M N O P
Q R S T U V W X Y Z

lowercase

a b c d e f g
h i j k l m n o p
q r s t u v w x y z

punctuation

. ! ? ... : ; , @ # % ^ & *
" " " " " " < > [] { } () \ | - _ _ _

numerals

1 2 3 4 5 6 7 8 9 0

table of contents

1. Inspiration

2. Wordlist

3. Metrics

4. Glyphs >

5. Samples

6. Usage

7. Colophon

accents

˘ ˙ ˆ ˜ ¨ ˆ ˆ ˆ ˆ ˆ ˆ
À Á Â Ã Ä Å
Æ Ç È É Ê Ë Ì Í Î Ï Ñ Ò
Ó Ô Õ Ö Ø Ù Ú Û Ü Ý

accents

ä á à â ã æ ç è é è ê
ï í î î ñ ö ó ò ô õ œ ù
ú û û ÿ ý

currency +
math

\$ € ¥ ¢ + = ± × ÷ °

more glyphs

ø Ø ð Ð f μ ρ ρ ß
† ‡ § ¶ © ® ™

table of
contents

1. Inspiration

2. Wordlist

3. Metrics

4. Glyphs

5. Samples >

6. Usage

7. Colophon

modern tech

user interface

visual

Do you wish to log out?

screen time

journey

homepage

social connection

table of contents

- 1. Inspiration
- 2. Wordlist
- 3. Metrics
- 4. Glyphs
- 5. Samples
- 6. Usage >
- 7. Colophon

Watch Trailer Now

Download

720p (88 MB)

1080p (150 MB)

Shopping Bag: **\$2,217.00**

Recently added items

Traffic cone icon (PSD) download now
2 x **\$1,090.50**

PSD resource is a realistic paper coffee cup icon
2 x **\$18.00**

PROCEED TO CHECKOUT

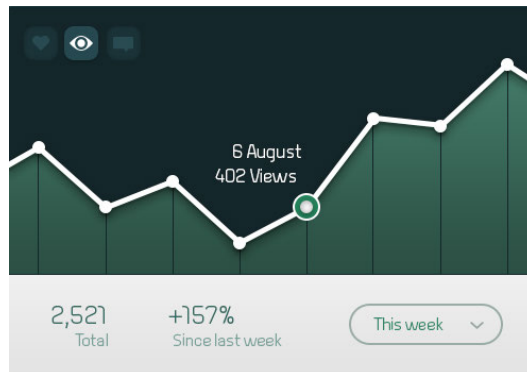

LEARN MORE



POPULAR ARTICLES

San Fran. 38°C
Today, Mon, August 5th, 2013

THUNDER TUES CLOUDY MON SUNNY SUN

DC Scarpelli
Typography Super Hero

Benjamin Michael Levy · Image: Benjamin Michael Levy

2:49 PM 80%

Track Title
Text

Now Playing

Track Title
Title
2013 - 60 Track (9:36:47)

Track Title

2:14 4:03

embarc

table of contents

1. Inspiration

2. Wordlist

3. Metrics

4. Glyphs

5. Samples

6. Usage >

7. Colophon

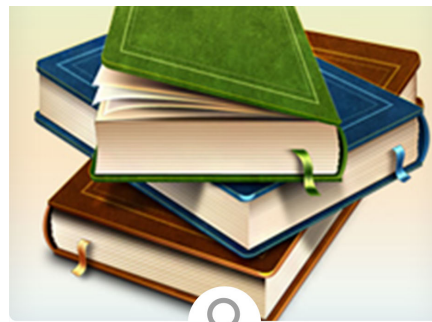

Stack of books icon in PNG and PSD format

\$268.00

ADD TO CART



Account Login

Remember Me

[Forgot Password?](#)

[New Here? Register Now](#)

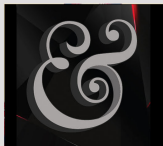

Michael
Administrator

Status: logged on
your account is locked

Please Enter Your Account Password

 New Message from Emmett Brown
Arrive on the roof of the school.

 Pick up Marty
in 9 minutes



Clean, Creative & Eye Catching

Fully Responsive & Optimized For All Screens

Well Commented & Documented

August 1st, 2013

Press Meeting 8:00 AM - 10:00 AM

Product Showcase 10:00 AM - 12:00 PM

Award Ceremony 5:00 PM - 7:00 PM

16:34 You wrote:

Vinyl single-origen coffee cardigan terry richardson, farm-to-table synth.

Squid next level farm-to-table photo booth.

Rosie wrote: 16:34

Gluten-free 8-bit 3 wolf moon messenger bag, Dreamcatcher +1 retro!

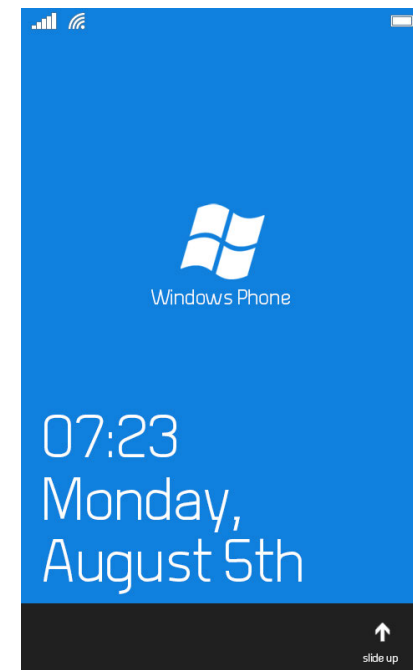
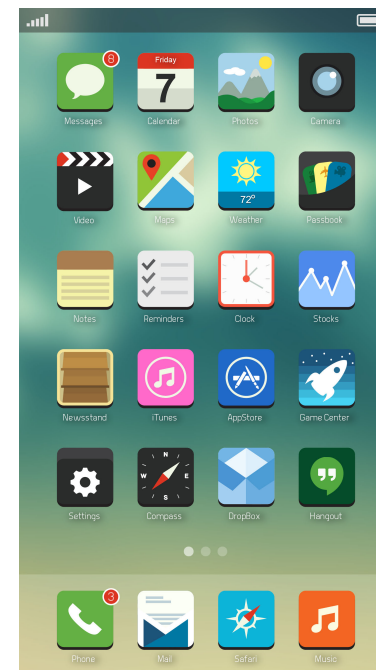

embarc light

is an original typeface designed by:

A handwritten signature in black ink, reading "BmL", with a fluid, cursive style.

BENJAMIN MICHAEL LEVY
new media designer

It was created during the summer of 2013
while enrolled in Type Design at the Academy of Art University.
The course was taught by DC Scarpelli, a very knowledgeable
and inspirational human being.